

# **I**NTERSTATE



## **30TDE**

**THE  
DEFINITION  
OF VALUE**

**TAPERED REAR END  
WITH RECESSED  
LIGHTS**

**LED LIGHTS & SEALED  
MODULAR WIRING**

**HEAVY DUTY SPRING  
SUSPENSION**

**(2) HEAVY DUTY  
CUSHION CYLINDERS**

**8 HOLE, HUB PILOTED  
STEEL DISC WHEELS**

**STRAIGHT-THRU  
CHASSIS DESIGN**

**UNDERCOATED**



TRAILERS, INC. 1101 HERITAGE PARKWAY MANSFIELD, TEXAS 76063

Visit our Web site at [www.interstatetrailers.com](http://www.interstatetrailers.com)

817/453-5402

800/433-5384

Fax: 817/453-5445

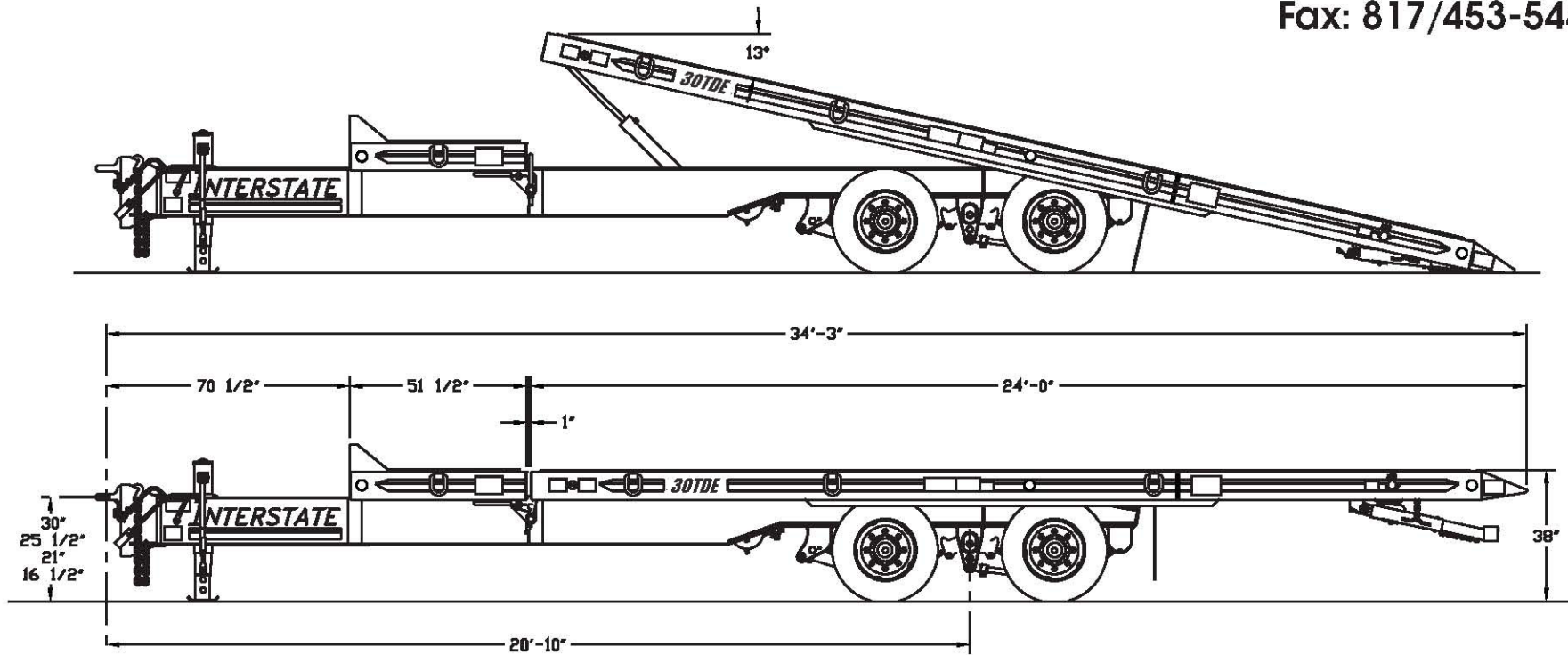

## Model: 30TDE

CAPACITY:	30,000 lbs. @ 55 MPH	Crossmembers:	Tilt Bed – S6" x 12.5# A572 Gr.50
Trailer Weight:	10,000#		High Tensile
Overall Length:	34' 3"	Chassis:	4" x 4" Rectangular Tube A500B
Overall Width:	102"	Heavy Duty Axles:	(2) 15,000 lb.
Tilt Deck Length:	24' 0"	Heavy Duty Brakes:	12-1/4" x 5" Electric
Stationary Deck:	51 1/2"	Heavy Duty Suspension:	Hutch 9700
Platform Height:	38"	Tires:	(8) 215/75R x 17.5 - 16Ply Radials
Decking:	2" Nominal Hardwood	Heavy Duty Wheels:	8 Hole, Hub Piloted Steel Disc
Hitch:	Adjustable Pintle Eye	Lights & Electric:	LED Lights and Sealed, Modular Wiring Harness, ICC & DOT Approved
Main Rails:	Tilt Bed W-8" x 15# A572 Gr 50 High Tensile	Heavy Duty Jack:	25,000# Two Speed Jack
Chassis:	W14" x 26# A572 Gr 50 High Tensile		

Your **INTERSTATE** Dealer Is

Interstate Trailers, Inc. reserves the right to change design, material and/or specifications without notice and without incurring any obligation to such changes.